

Anexo L

Sistema de Señalización Vial Uniforme

Ley 24.449 Artículo 22
Decreto Reglamentario 779/95



**SEGURIDAD
VIAL**



Ministerio de Transporte
Argentina

SEÑALES REGLAMENTARIAS O PRESCRIPTIVAS | De prohibición



No avanzar
R1



Contramano
R2



Prohibición de circular (Autos)
R3



Prohibición de circular (Motos)
R3



Prohibición de circular (Bicicletas)
R3



Prohibición de circular (Camión)
R3



Prohibición de circular (Acoplado)
R3



Prohibición de circular (Peatón)
R3



Prohibición de circular (Tracción animal)
R3



Prohibición de circular (Animal)
R3



Prohibición de circular (Carro de mano)
R3



Prohibición de circular (Tractor)
R3



No Girar a la Izquierda
R4



No Girar a la Derecha
R4



No Girar en U (No retomar)
R5



Prohibido Adelantar
R6



No Ruidos Molestos
R7



No Estacionar
R8



No Estacionar Ni Detenerse
R9



Prohibición de Cambiar de Carril
R10

SEÑALES REGLAMENTARIAS O PRESCRIPTIVAS



Limitación de peso
R 11

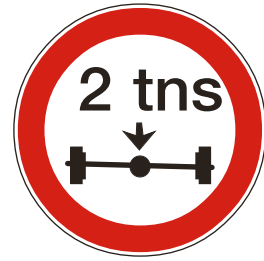

Limitación de peso por eje
R 11



Limitación de altura
R 12



Limitación de ancho
R 13



Limitación de largo
R 14



Límite de velocidad máxima
R 15



Límite de velocidad mínima
R 16

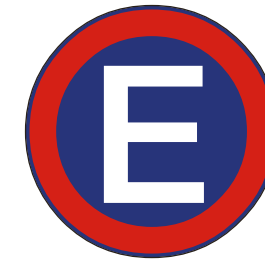

Estacionamiento exclusivo
R 17



Circulación exclusiva (transporte público)
R 18

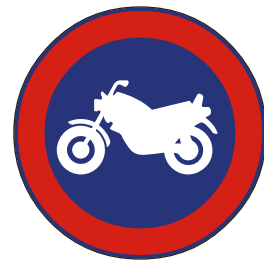

Circulación exclusiva (motos)
R 18



Circulación exclusiva (bicicleta)
R 18

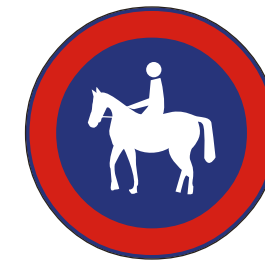

Circulación exclusiva (jinetes)
R 18

SEÑALES REGLAMENTARIAS O PRESCRIPTIVAS | De restricción



Circulación exclusiva (peatones)
R 18



Uso de cadenas para nieve
R 19



Giro obligatorio (derecha)
R 20



Giro obligatorio (izquierda)
R 20



Sentido de circulación (derecha)
R 21



Sentido de circulación (izquierda)
R 21



Sentido de circulación
(Comienzo sentido único)
R 21



Sentido de circulación (alternativa)
R 21



Paso obligado (derecha)
R 22



Paso obligado (izquierda)
R 22



Tránsito pesado a la derecha
R 23



Peatones por la izquierda
R 24



Puesto de control
R 25



Comienzo de doble mano
R 26



Transitar con luces bajas encendidas
Ley N° 25456



Pare
R 27



Ceda El paso
R 28

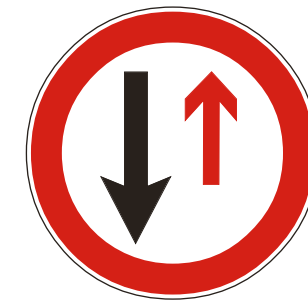

Preferencia de avance
R 29

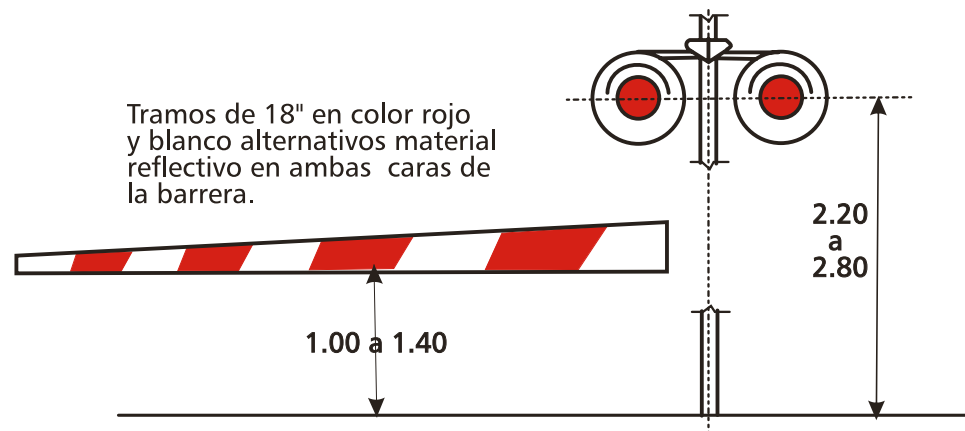

Barreras ferroviarias R 30

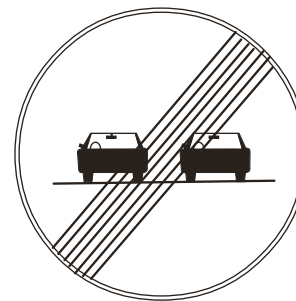

Fin de prescripción
R 31



Fin de prescripción
R 32

SEÑALES PREVENTIVAS | Advertencia de máximo peligro



Crucé ferroviario
P1

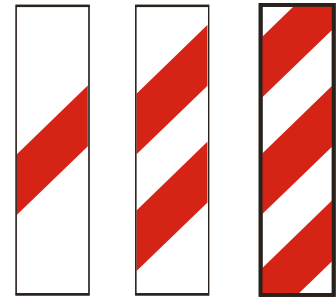

Paneles de prevención (aprox)
P2



Paneles de prevención (obstáculo rígido)
P2



Paneles de prevención (curva)
P2



Paneles de prevención (curva)
P2

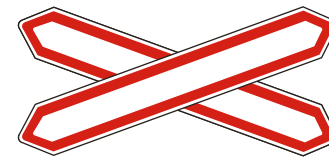

Cruz de San Andrés
P3

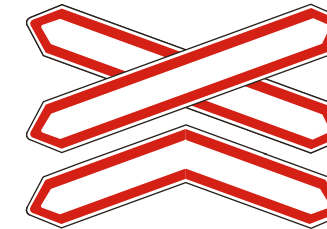

Cruz de San Andrés
P3



Curva cerrada
P4



Cruce de peatones
P5



Atención
P6

SEÑALES PREVENTIVAS | Posibilidad de riesgos eventuales



Escolares
P 25



Niños
P 25



Ciclistas
P 26



Jinetes
P 26



Animales sueltos (vaca)
P 27



Animales sueltos (ciervo)
P 27



Corredor aéreo
P 28



Presencia de vehículo extraño (tranvía)
P 29



Presencia de vehículo extraño (tractor)
P 29



Presencia de vehículo extraño (ambulancia)
P 29



Vientos fuertes laterales
P 30

SEÑALES PREVENTIVAS | Advertencias sobre características físicas de la vía



Puente móvil
P 17



Altura limitada
P 18



Ancho limitado
P 19



Calzada dividida
P 20



Rotonda
P 21



Incorporación de tránsito lateral
P 22



Inicio de doble circulación
P 23



Encrucijada (cruce)
P 24



Encrucijada (Empalme)
P 24



Encrucijada (bifurcación)
P 24



Encrucijada (bifurcación alternativa)
P 24

SEÑALES PREVENTIVAS



Curva (común)
P 7



Curva (contracurva)
P 7



Curva (en "S")
P 7



Camino sinuoso
P 8



Pendiente (descendente)
P 9



Pendiente (ascendente)
P 9



Estrechamiento (en las dos manos)
P 10



Estrechamiento (En una sola mano)
P 10



Perfil irregular (Irregular)
P 11



Perfil (irregular badén)
P 11



Perfil irregular (lomada)
P 11



Calzada resbaladiza
P 12



Proyección de piedras
P 13



Derrumbes
P 14



Túnel
P 15

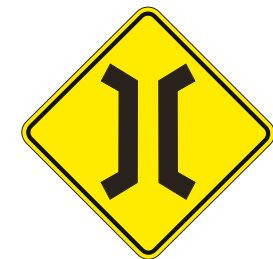

Puente angosto
P16

SEÑALES PREVENTIVAS | Anticipo de otros dispositivos de control de tránsito

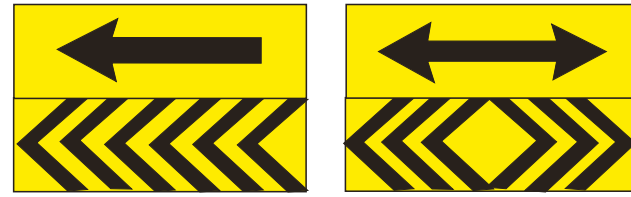

Flecha direccional
P 31



Proximidad de semáforo
P 32



Proximidad de señal restrictiva (pare)
P 33



Proximidad de señal restrictiva (pasó)
P 33



Proximidad de señal restrictiva otras
P 33

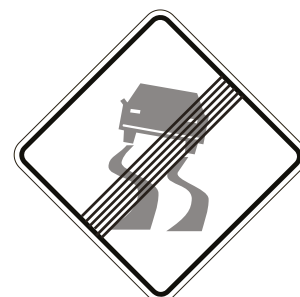

Fin de prevención
P 34

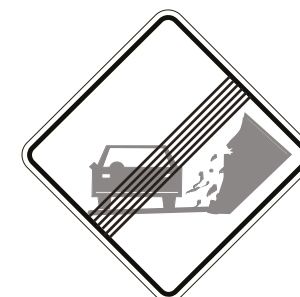

Fin de prevención
P 34



Ruta Panamericana
11



Ruta nacional
12



Ruta provincial
13



Nomenclatura urbana
14



Nomenclatura urbana
14



Identificación de región y localidades
15



Orientación (en caminos primarios y secundarios)
16



Orientación (en camino secundarios)
17



Comienzo o fin de zona urbana
18



Identificación de jurisdicción o acceso geográfico
19



Mojón kilométrico
110



Nomenclatura de autopista
111



Comienzo de autopista
I 12



Fin de autopista
I 13

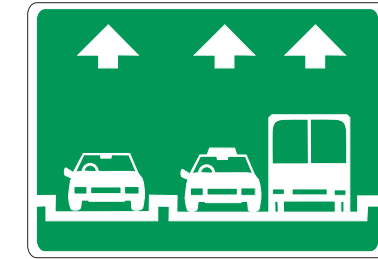

Indicación de utilización de carriles
I 14

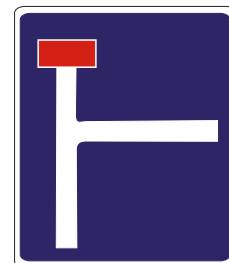
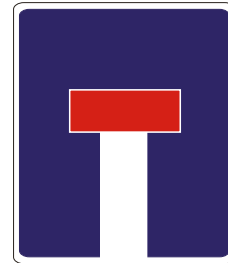

Camino o calle sin salida
I 15



Camino paso transitable
I 16

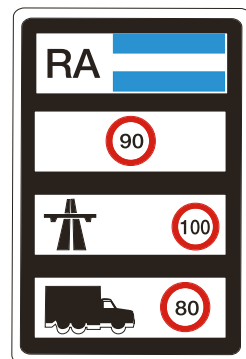

Velocidades máximas permitidas
I 17

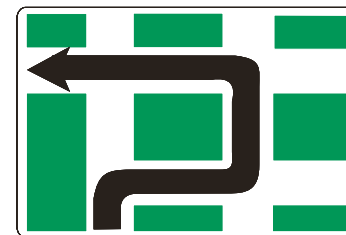

Esquema de recorrido
I 18

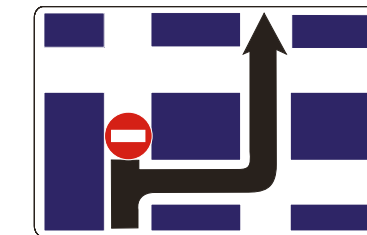

Desvío por cambio de sentido de circulación
I 19

SEÑALES INFORMATIVAS



Estacionamiento permitido
120

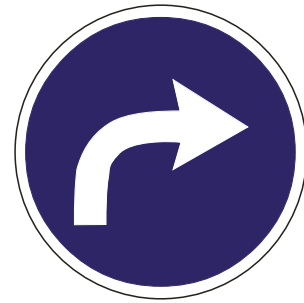

Permitido girar (derecha)
121

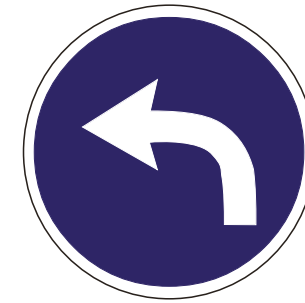

Permitido girar (izquierda)
121

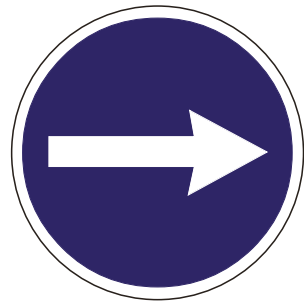

Direcciones permitidas (derecha)
122



Direcciones permitidas (izquierda)
122

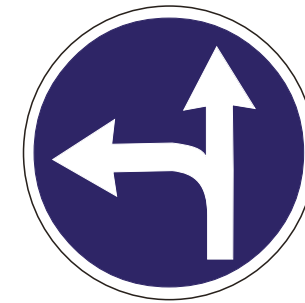

Direcciones permitidas (igual sentido o izquierda)
122

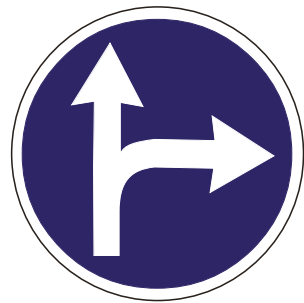

Direcciones permitidas (igual sentido o derecha)
122

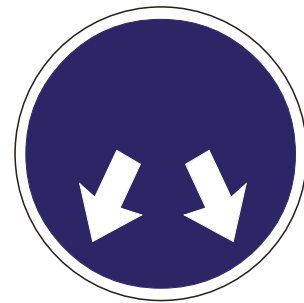

Direcciones permitidas (ambas direcciones)
122



Direcciones permitidas (bifurcación)
122

SEÑALES INFORMATIVAS | Información turística y de servicios

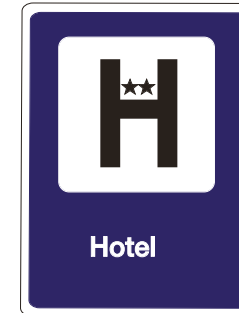

DEMARCACIÓN HORIZONTAL

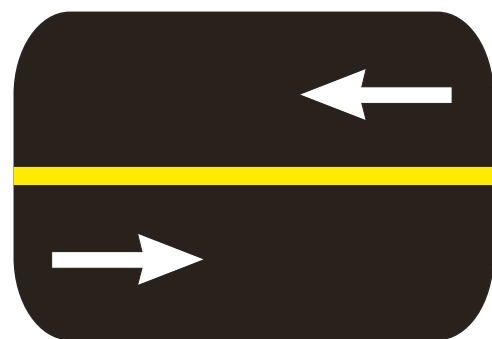

H1
Línea de separación de sentido de circulación
Línea individual continua

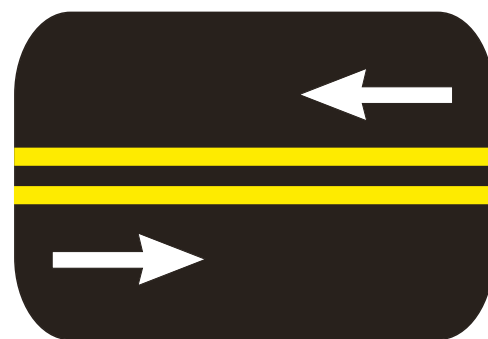

H1
Línea de separación de sentido de circulación Líneas divisorias paralelas continuas

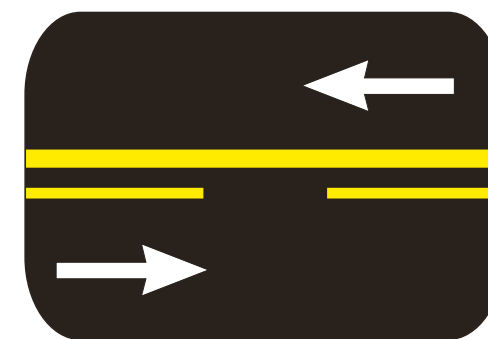

H1
Línea de separación de sentido de circulación Línea divisoria continua paralela a otra discontinua

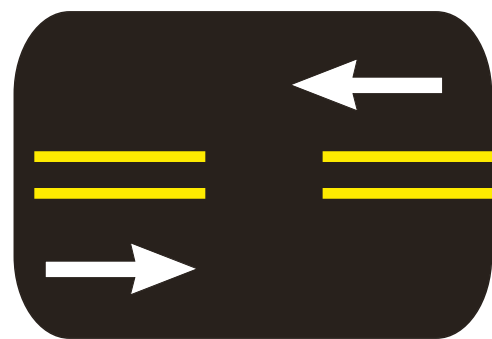

H1
Línea de separación de sentido de circulación Líneas divisorias paralelas discontinuas para carriles reversibles

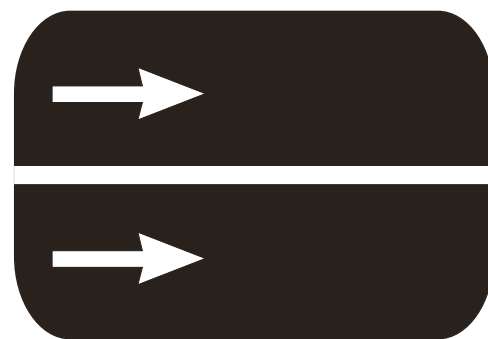

H2
Línea de carril
Línea continua divisoria de corrientes del mismo sentido

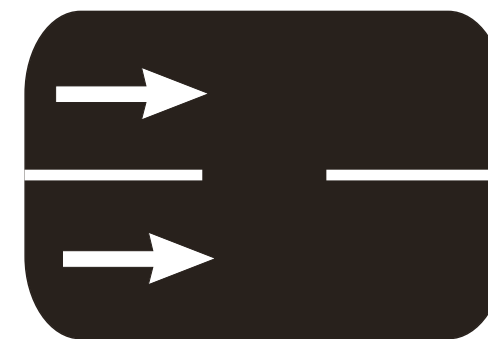

H2
Línea de carril
Línea discontinua divisoria de corrientes del mismo sentido

DEMARCACIÓN HORIZONTAL

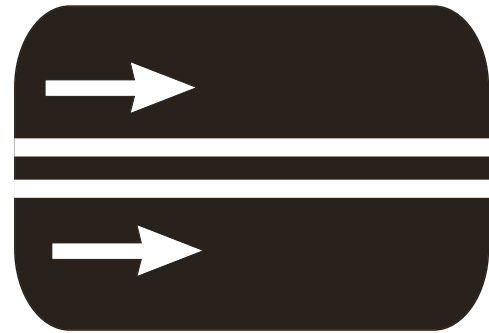

H2
Línea de carril exclusivo
Doble línea continúa

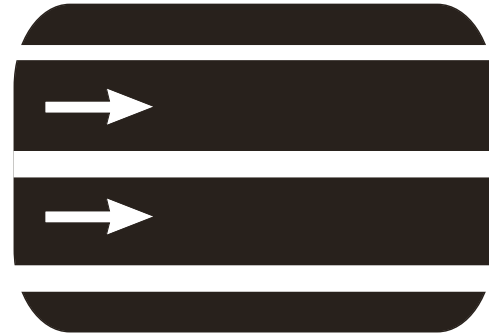

H2
Línea de carril preferencial
Línea del carril de mayor ancho

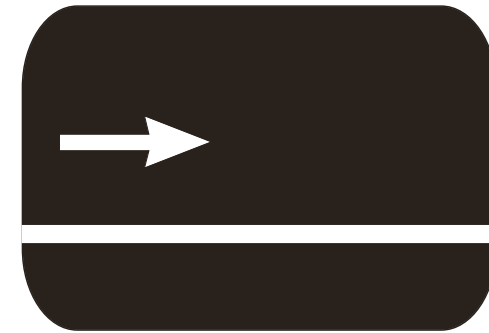

H3
Línea de borde de calzada
Línea continúa

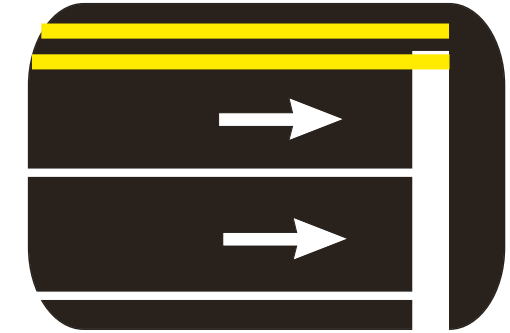

H4
Marcas transversales
Línea de detención

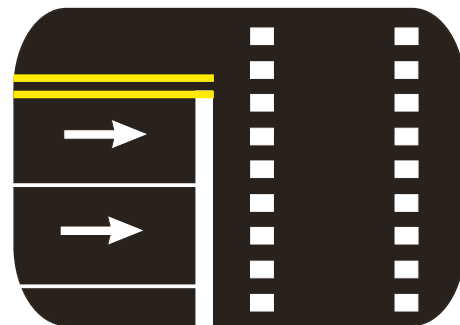

H5
Senda peatonal

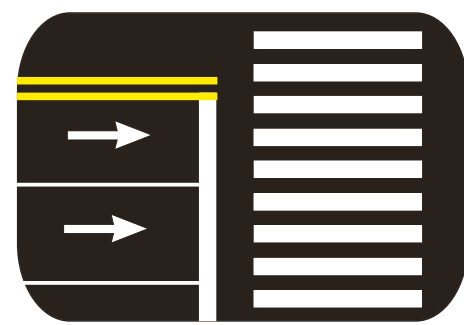

H5
Senda peatonal (cebrado)

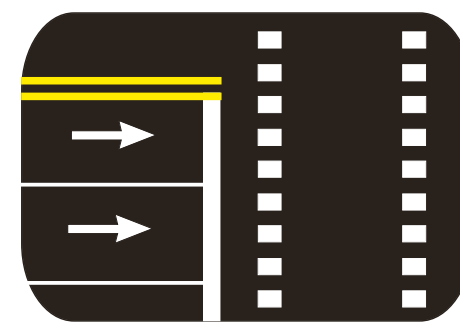

H5
Senda para ciclista

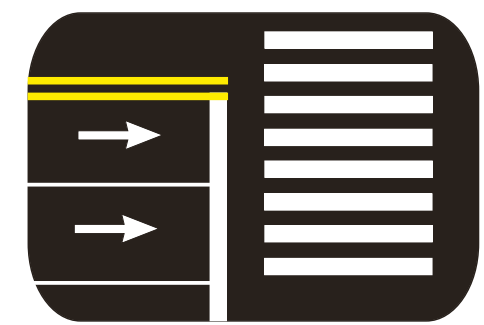

H5
Senda para ciclista (cebrado)

DEMARCACIÓN HORIZONTAL

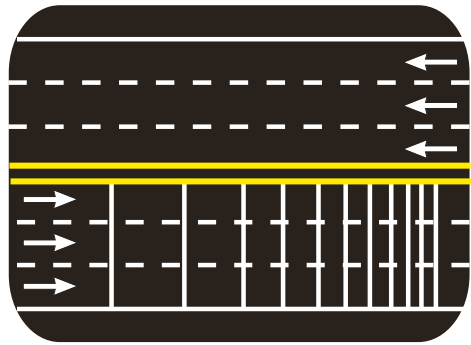

H7
Líneas auxiliares para reducción de velocidad

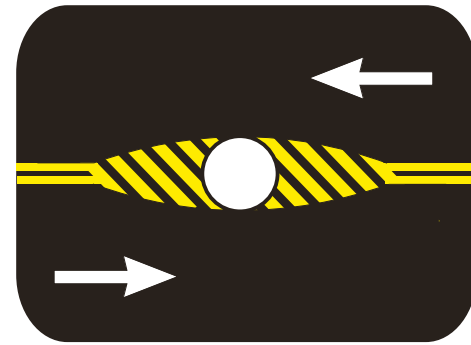

H8
Marcas especiales Marcas canalizadoras de tránsito (e isletas)

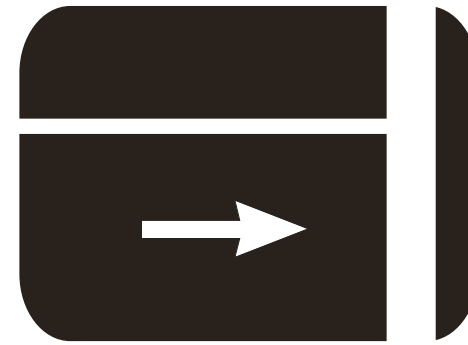

H9
Flecha simple



H9
Flecha curvada



H9
Flecha combinada



H10
Pare



H11
Estacionamiento (Paralelo)



H11
Estacionamiento (90°)

DEMARCACIÓN HORIZONTAL

P			80			E
Parada de Transporte	Carril Exclusivo	Carril Emergencia	Máxima	Carril Exclusivo	Ceda el Paso	Estacionamiento

H12
Inscripciones



H13
Cruce ferroviario

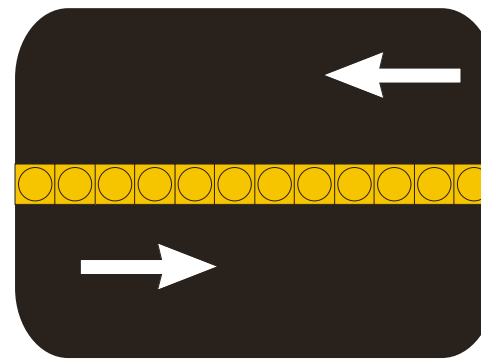

H14
Separador de tránsito

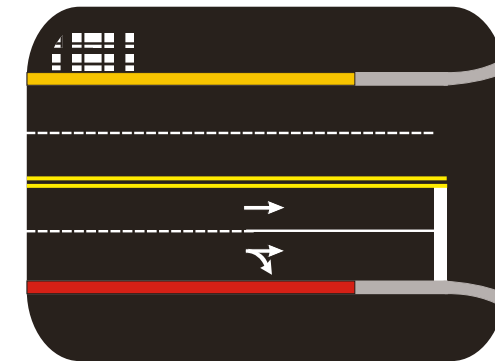

H15
Cordones pintados

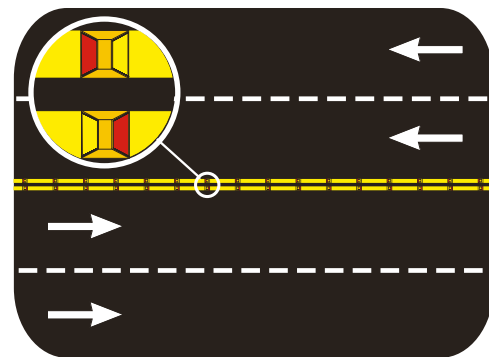

H16
Tachas

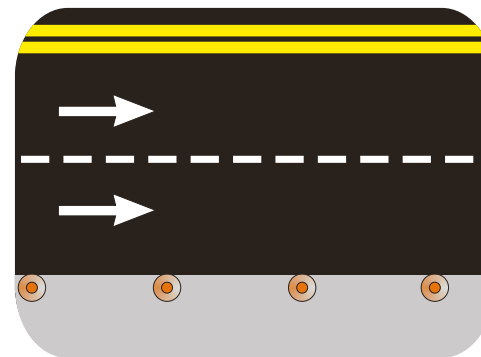

H17
Delineadores (conos)

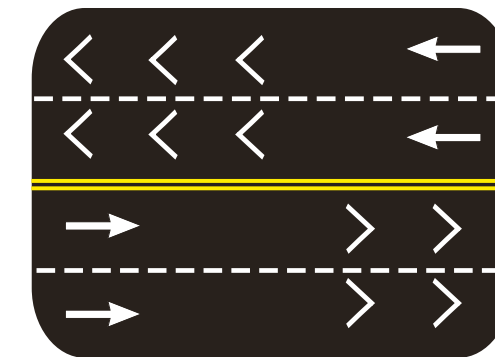

H18
Para niebla

DEMARCACIÓN LUMINOSA



Semáforo con visera

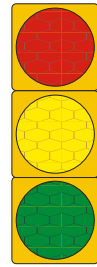

Semáforo sin visera

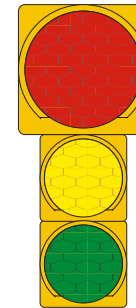

Semáforo de gran sección roja con visera

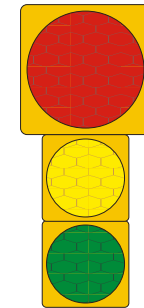

Semáforo de gran sección roja sin visera



Flecha vertical para seguir al frente

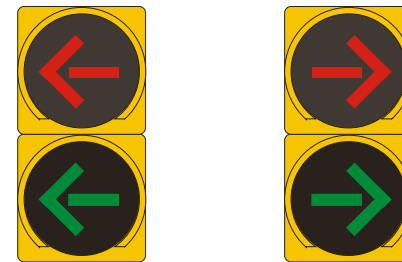

Flecha horizontal para seguir a la izquierda o derecha



Semáforos especiales para peatones

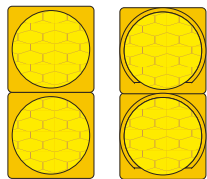

Semáforos especiales Intermitentes

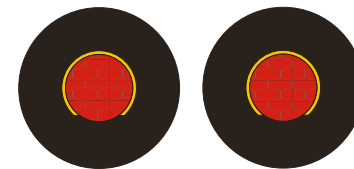

Semáforos especiales para cruce ferroviario



Semáforos especiales para carriles reversibles

DEMARCACIÓN TRANSITORIA



Calle o carretera en construcción o cerrada
T1



Desvío
T2



Carretera de un solo carril
T3



Estrechamiento de calzada
T4



Banderillero
T5



Hombre trabajando
T6



Equipo pesado en la vía
T7



Trabajos en la banquina
T8

DEMARCACIÓN TRANSITORIA



Zona de explosivos
T 9



Longitud de la construcción
T 10



Fin de construcción
T 11

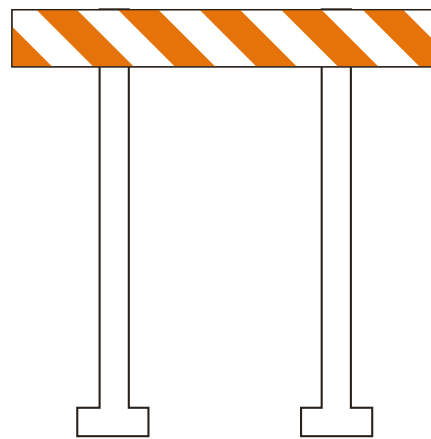

Vallas
(tipo I)

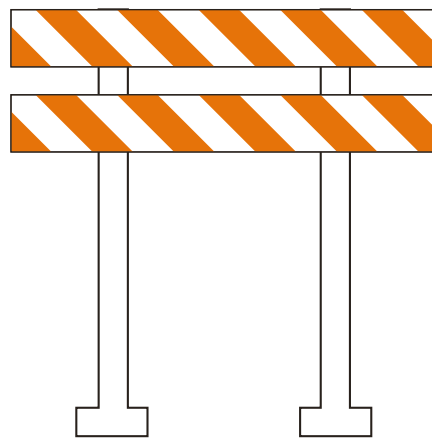

Vallas
(tipo II)

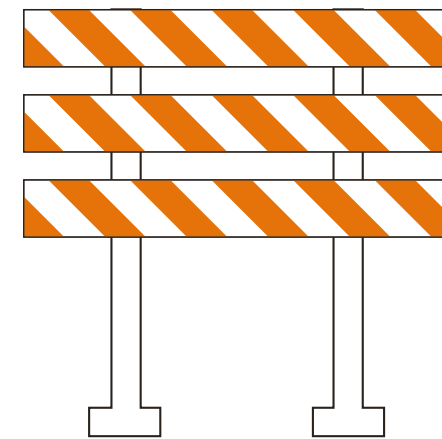

Vallas
(tipo III)

DEMARCACIÓN TRANSITORIA

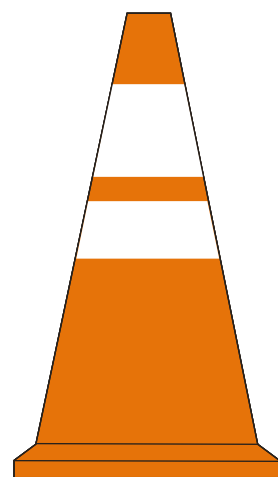

Conos

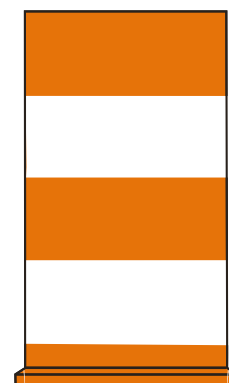

Tambores

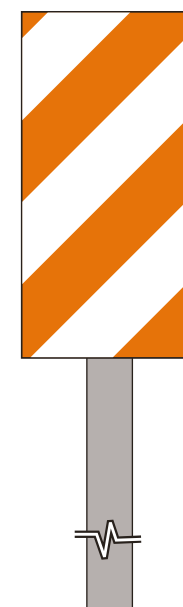

Delineadores

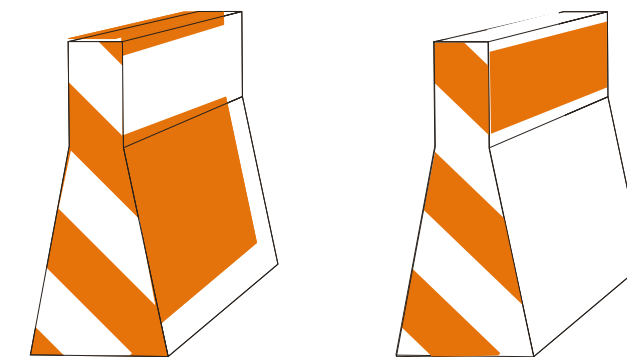

Muro Jersey



Peatones

En zonas urbanas los peatones deben transitar:

- Por la vereda o espacios habilitados para tal fin.
- Cruzar por las esquinas con la senda peatonal respetando el semáforo y mirando hacia ambos lados antes de hacerlo.
- Evitar el uso de celulares u otros dispositivos que causen distracción.

En zonas rurales los peatones deben transitar:

- Por sendas o lugares lo más alejado posible de la calzada.
- Por la banquina en sentido contrario al tránsito.
- Durante la noche con brazaletes u otros elementos retroreflectivos para ser vistos.
- Cruzar en forma perpendicular a la calzada, respetando la prioridad de los vehículos.



Prioridades

En las intersecciones, ceder siempre el paso al que circula por la derecha, salvo cuando:

- La señalización indique lo contrario.
- Se trata de cruces ferroviarios, o vehículos de servicio de urgencia, o vehículos que provengan de una semiautopista.
- Los peatones crucen por lugares habilitados.
- Se desemboca desde una vía de tierra o pavimentada, se circule el costado de vías férreas, respecto del que sale del paso a nivel.
- Se detenga la marcha o se gire para ingresar a otra vía.
- Se conduzcan animales o vehículos de tracción a sangre.
- Si se dan juntas varias excepciones, la prioridad es según el orden aquí indicado.
- Para cualquier otra maniobra, goza de prioridad quién conserva su derecha.

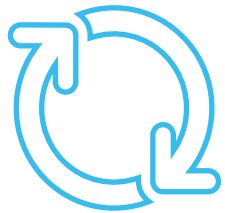

Giros y rotondas

- Tanto en los giros y rotondas es importante respetar la señalización indicada para una conducción segura en la vía pública.
- Al ingresar a una rotonda advertir las maniobras con suficiente antelación, mediante la señal luminosa correspondiente y mantenerla hasta la salida.
- Circular treinta metros antes por el costado más próximo del giro efectuar.
- Reducir la velocidad paulatinamente, girando a una marcha moderada.
- La circulación alrededor de una rotonda no debe ser interrumpida. Tiene prioridad de paso el que circula por ella sobre el que intenta ingresar, debiendo cederla al que ingresa salvo señalización de en contrario.







Sistema de retención infantil (SRI)

Los sistemas de retención infantil mantienen a los niños firmemente asegurados a su asiento, para que en el caso de una maniobra brusca el niño no se expulsado del vehículo.

- Los menores de 10 años de viajar sujetos al asiento trasero con el correa correspondiente y los menores de 4 años deben viajar en los dispositivos de retención infantil correspondiente.
- Los bebés menores a 9 meses deben viajar en un SRI apropiado para su peso y mirando hacia atrás, en sentido contrario a la marcha del vehículo.
- No se debe llevar al niño en el regazo, tampoco compartir el cinturón.
- Es importante asegurarse de que la silla corresponde al peso y tamaño del niño.

Vías semaforizadas

-  **Verde:** avanzar
-  **Roja:** detenerse antes de la línea marcada a tal efecto o de la Senda peatonal.
-  **Amarilla:** detenerse si se estima que no se alcanzará a transponer la encrucijada antes de la roja.
-  **Intermitente amarilla:** que advierte la presencia de cruce riesgoso, aminorar la marcha y efectuar el mismo con precaución.
-  **Intermitente roja:** que advierte la presencia de cruce peligroso, detener la marcha y sólo reiniciarla cuando se observe que no existe riesgo alguno.

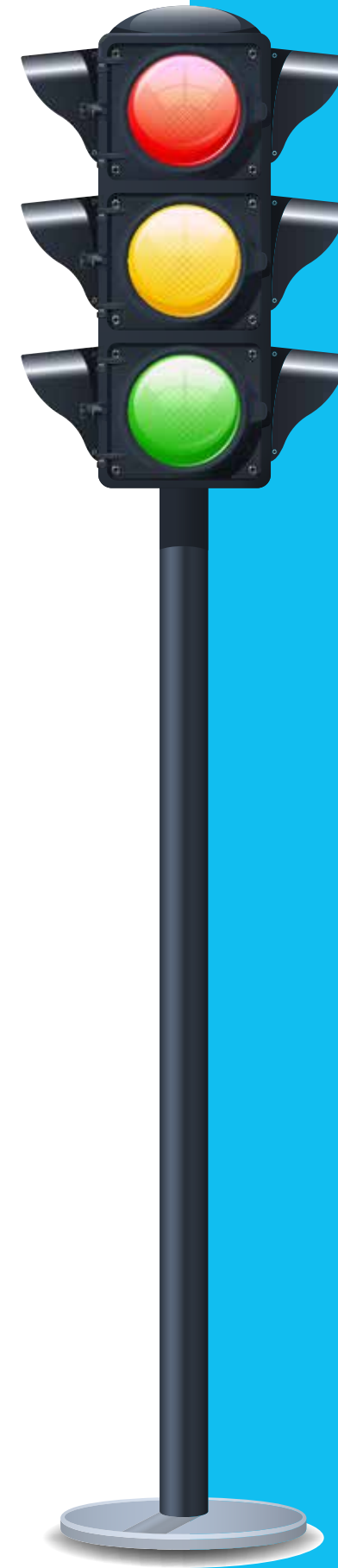



Respetá las velocidades máximas

Excederlas es una de las causas principales de los siniestros viales.



Usá siempre el cinturón de seguridad

Reduce el riesgo de sufrir lesiones graves y de muerte ante un siniestro vial.



En moto o cuatriciclo usá siempre el casco

El uso del casco puede salvar tu vida en una caída o siniestro vial.



No tomes alcohol antes de manejar

El alcohol en sangre altera tus sentidos y disminuye su capacidad de reacción.



No uses el celular mientras manejas

Te distrae y te quita atención a lo que sucede en la vía pública.

www.argentina.gob.ar/seguridadvial

   /InfoSegVial

SEGURIDAD
VIAL



Ministerio de Transporte
Argentina